

Product Information Sheet

The **Safe SingleDRIFTER™** is a safe, efficient and engineered approach to drifting singles of drill pipe on the catwalk during pick-up operations, prior to inclusion in the drill string or racking back in the derrick. The system eliminates the risk of a heavy drift, often rig manufactured, knocking off or severely damaging the metal or plastic thread protector and allowing the drift to fall out potentially causing injury. The tool also eliminates the risk of a thread protector being removed from the drill pipe whilst suspended with a drift lodged inside that may subsequently free itself and fall out. The tool comprises two purpose built parts, a lightweight drift and a drift catching thread protector.

The sturdy but lightweight drift catching thread protector is easy to thread on and off the pin end of the drill pipe to be drifted, due to its size, shape and grooved outer diameter. The catcher has view ports in its side and end. The ports are used to visually confirm that the drift has landed and is seated in the catcher before the assembly is removed. The drift has an indicating rod at each end that will protrude slightly from the bottom of the catcher when the drift is in place. Together both items are lightweight and easy to remove from the drill pipe once the drift has landed. The drift seats in the catcher protector and will remain there whilst it is unthreaded and removed by the operator.

If the drift is not observed when the pipe is picked up sufficiently to allow the drift to slide down and enter the catcher then extra precautions can be taken prior to removing the protector. The pipe could be shaken or bumped to dislodge the drift inside, still with the catcher in place, or the pipe could be laid down again for closer inspection and manual removal of the drift by hand with rods. The failure to drift the single joint could lead to it being set aside and not used.

However in the normal course of events the pipe is picked up, the drift is observed sitting in the catcher and the assembly is easily and safely removed ready to drift the next piece of drill pipe to be picked up.

DRILL PIPE DRIFTING TOOL
w/ 4-1/2" API IF CONNECTION

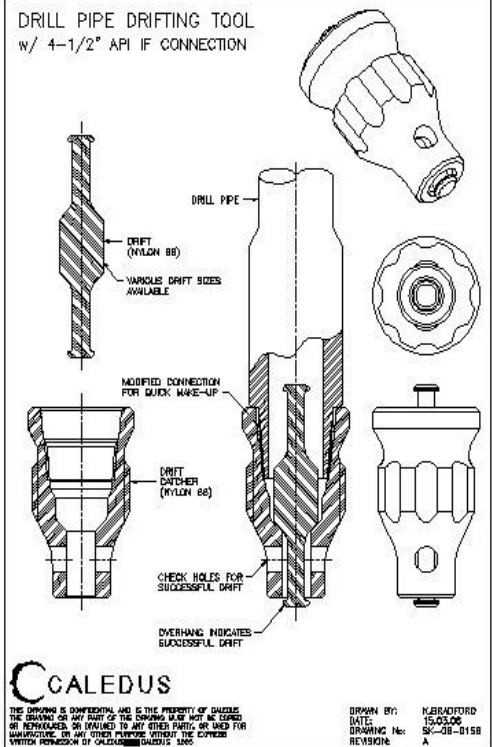

Safe SingleDRIFTER™

Caledus UK Ltd
4 Rubislaw Terrace
Aberdeen
AB10 1XE

Tel: +44 (0) 1224 659000
Fax: +44 (0) 1224 659001
www.caledus.com